

Transformation of the collagen structure during beam-house processes and combined tanning

Viktor Lischuk, Viktoriya Plavan and Anatolij Danilkovich

Department of Leather and Furs Technologies, Kiev National University of Technology and Design, Nemirovich-Danchenko 2, 02011 Kiev, Ukraine; chemi@mail.kar.net

Received 24 October 2005, in revised form 29 June 2006

Abstract. The characteristic features of forming the collagen structure in the beam-house process and tanning have been investigated. It is shown that the moderate derma-swelling rate during liming provides effective fixation of the derma structure in tanning. The formation of strong cross-linkages during tanning leads to the change in the deformation character of derma collagen, especially in the compression test. The usage of the glutaric aldehyde by tanning allows to reduce the consumption of chrome compounds or fully exclude them and at the same time to receive soft elastic leather with a high volume yield.

Key words: collagen structure, derma, liming, tanning, swelling index, structuring, glutaric aldehyde, elasto-plastic properties, volume yield.

1. INTRODUCTION

For the development of new and perfection of existing tanning technologies, it is necessary to understand profoundly and comprehensively the characteristic features of chemical composition and structural transformation of derma collagen. Multilevelling collagen structure, as a protein basis of the raw material of leather, stipulates the complexity and labour intensity of technological processes of leather production. In spite of being known for many years, the technology of leather raw material re-cycling and the development of new low-waste and more eco-friendly technologies are still actual problems.

The efficiency of the technology of animal skin processing is, first of all, stipulated by the level of carrying out soaking-liming, including tanning, processes, in which mainly the micro- and macrostructure derma collagen have to be formed [¹]. While processing animal skins, the dynamic destruction of different types of linkages takes place between fibrous elements of the protein of

high molecular weight at different levels of its organization and appearance of new links by using reagents.

While soaking and liming, as a result of removal of non-collagen formations, such as hairs, epidermis, subcutaneous fat muscular layer, mucopolysaccharides, lipids, etc., the derma collagen structure is formed. At the same time, it is substantial to save the primary amino acid compound with the definite rate of hydrophily after skin soaking and stabilization of the collagen structure after skin liming is required for its consolidation in the following processing stages. In order to obtain high-quality leather on each stage of the technological process, it is necessary to realize optimal conditions for the micro- and macrostructure of the derma and the collagen hydrophily rate.

The aim of this investigation is the determination of the interconnection between physical-chemical properties of the derma collagen and its structural transformation during the beam-house process and combined tannage. We investigate the structure of the derma collagen and peculiarities of its formation during the beam-house process and combined tannage.

2. THE OBJECT AND METHODS OF INVESTIGATION

The collagen macromolecule consists of three polypeptide chains, the distance between the centers of which is 0.6 nm [2]. The helix macromolecule conformation with the space of 87 nm is finished by unspiraled sector. The protein macromolecules consist of various collagen types. They have different chemical and geometrical structure, at the same time, the skin composition includes 7 types from the well-known 20 [3]. The types I, III, IV, V (Table 1) belong to the main ones. They vary in the primary structure, stipulated by the order in amino acid residuals in polypeptide chains, and the remaining collagen types also differ by the geometrical form of elementary fibres. The collagen types I and III are covalently bound to each other. The collagen fibrils I, III and V are characterized by crossing banding with the periodicity of 700 nm. Three IV-type collagen chains are formed in a triple helix with the length of 400 nm. These chains form a helix with the great well-ordered C-terminal and small N-terminal of unknown structure. The collagen type IV, present in the epidermis layer, forms a cross-linked structure and after removal of the corneal layer it provides the leather grain [4].

The considered collagen structure stipulates a variety of interchains and interturn links, formed as a result of interoperated functional groups of side radicals of neighbouring polypeptide chains and turns. Each polypeptide group can form two hydrogen links with other groups. The collagen structure has relatively well ordered hydrophobic areas, formed by hydrocarbon links of polypeptide chains. These are located at a minimum distance from one another. Due to this, these areas are almost impassable for penetration of the chemical compounds. The unordered hydrophilic areas are formed through availability of a great number of side chains, the distances between them are changed and might be rather substantial [5]. The length of hydrophilic sectors along polypeptide chains

Table 1. Main collagen types of animal fells

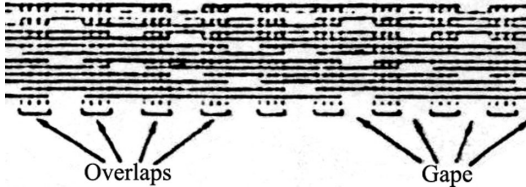
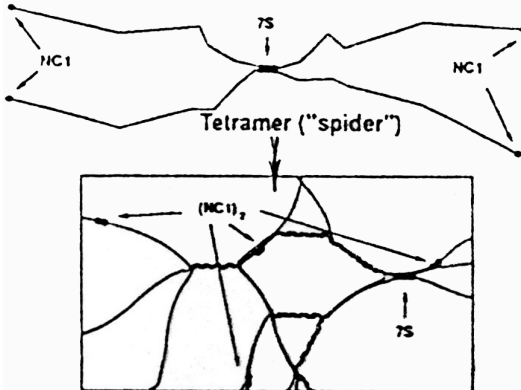
Type	Molecular formula [4]	Tissues distribution	Schematic drawing [3]
Collagens of fibril formation			
I	$[\alpha_1(I)]_2 \alpha_2(I)$	Skin, bones, tendon, ligaments	
III	$[\alpha_1(III)]_3$	Skin, blood vessels	
V	$[\alpha_1(V)]_2 \alpha_2(V)$	As for type I	
Collagen forming sheets			
IV	$[\alpha_1(IV)]_2 \alpha_2(IV)$	Basal laminae	

is in the range of 20–40 Å [6]. Hydrophobic crystal areas are interleaving with hydrophilic amorphous areas.

The derma structure is formed by collagen fibre bundles [7]. The elementary fibres are located parallel in bundles [2]. The fibre bundles are interlaced at different angles of inclination to derma surface. The fibrils are characterized by amorphous and crystalloid structure, taking into account the fact that the volume of crystalline regions gains 60%. The microfibril (the diameter of which changes depending on the water content) consists of five macromolecules with subsequent offset by 67 nm that corresponds to 235 amino acid residual. The beginning and end of macromolecules are covalently bound in a single pentamer. The distance between the centres of neighbouring macromolecules is 1.5 nm in the case of collagen humidity of 60%. The features of the fibrous structure of the derma are shown in Table 2.

In order to investigate the collagen transformations in the leather manufacturing processes, a complex of physical, chemical and analytical methods was used.

Table 2. Short characteristics of collagen structure levels

Structure		Characteristics
Level	Name	
1	polypeptide	the order of location of amino acid residuals in polypeptide chains
2	helix	the formation of polypeptide chains in the helix, where amino acid residuals are located radially to the axis of the helix, twisted to the left with the cycle in three amino acid residuals per one turn (step)
3	molecular	the formation of macromolecules out of three left-twisted helices, twisted to the opposite side; length is 300 nm and diameter 1.5 nm
4	permolecular	the formation of microfibrils from five macromolecules with a diameter of 3–5 nm, from 900 to 2000 microfibrils are combined into fibrils with a diameter of 50 to 200 nm
5	over-fibrillary	formation of filaments from 900 to 1000 fibrils with the diameter of 5×10^3 nm with subsequent interlace of 30–300 of elementary fibres into fibre bundles with a diameter of 0.2×10^6 nm
6	derma	mixing the bundles of elementary fibres with their orientation in different directions

Unsplitted hide of bulls of the thickness of 3–4 mm was taken for investigation. In order to exclude the influence of topographic differences on the derma microstructure, hide butt was used.

While investigating the process of liming, the degree of derma collagen swelling, the shrinkage temperature of the pelt and semi-finished item, the porosity of pelt, the content of calcium in pelt and the changing of the hide area were determined. The degree of derma collagen swelling after liming was determined with the gravimetric method. The growth of the sample weight after liming relative to natural collagen of 70% humidity was measured. The porosity of the hide for ether and spirit drying and other indices were determined according to [8].

The shrinkage temperature was determined with the help of an apparatus, shown in Fig. 1. Water or a mixture of water with glycerin (1 : 1) is poured into the vessel. Sample 11 is fixed on hooks 10 and 12. Thread 8 with load 4 is thrown over roller 5 which is fixed on the post 2. Pointer 6 (which is connected with the roller) is set on zero of the scale 7. The position of the thermometer 9 is controlled and its small ball must be at the bottom of the sample. The vessel is closed by a cover 3. The shrinkage temperature of pelt and semi-finished item corresponded to the thermometer reading at the moment of the sample shrinkage during heating in water with a speed of 2°C in a minute with an accuracy of $\pm 0.5^\circ\text{C}$.

For studying the combined tanning process, non-splitted ox-hide with a thickness of 3–4 mm was used. In order to remove the influence of topographical differences on derma microstructure, the butt part of the pelt was used. While studying the process of combined tanning, the shrinkage temperature of the pelt and semi-finished item, apparent semi-finished item density, volume yield (leather volume in cm^3 which contains 100 g of protein), tensile strength at

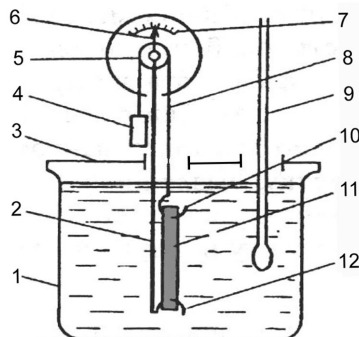

Fig. 1. Scheme of the instrument for measuring the shrinkage temperature.

stretching, relative elongation at stress 9.8 MPa and leather deformation properties under compression were determined.

The apparent semi-finished product density was determined as the ratio of the leather mass to its full volume, including pores [8]. The leather mass was determined by weighing. The apparent leather volume was determined using a liquid, which fills the pores (for example, kerosene). According to this method, the sample of leather was put into a retort of 50 cm³ (V_0), filled with kerosene. Kerosene volume V_1 in cm³ was determined. Measured retort was closed by cork and left for twenty four hours. During this time, the leather pores were filled with kerosene, its level in the retort lowered for the volume of filled pores. Then, with kerosene level at the mark, volume V_2 was fixed. The real sample volume was calculated as

$$V_r = V_0 - (V_1 + V_2).$$

Kerosene from the measured retort was poured off, the pieces of pelt were shaken out, dried with the filter paper and again placed into the measurement retort. Kerosene was poured in, the volume of kerosene V_3 was measured. The apparent sample volume was calculated as

$$V_a = V_0 - V_3.$$

Then the apparent density was calculated as

$$\rho_a = m/V_a,$$

where m is the weight of the sample.

Stretching the leather, the tensile strength and elongation at the stress 9.8 MPa were determined. These indices are regulated by the State Standard of Ukraine for most types of leather. The tests were carried out with breaking machine RT-250. For testing, samples were chosen from each leather, half of them longitudinal (parallel to back-bone) and the other half diametrical. The final result was calculated as an average arithmetical value for longitudinal and

diametrical samples. The precision of the breaking machine was 1%. Before testing, on the scale of loads, the control needle is set at the mark, which corresponds to the stress of 9.8 MPa. When subsequently stretched, the sample elongation is recorded at the moment of contact of working needle with the control one. The load is determined at the moment of the breakage of the sample and maximum elongation is measured. These data are used for the calculation of the ultimate tensile strength and relative elongation at a stress of 9.8 MPa.

The investigation of leather deformation properties for different kinds of tanning was conducted by means of measuring the thickness of derma samples by compression [9]. For each series of tests homogenous samples were taken of the size of 150 × 200 mm. The preparatory processes were conducted in the same way. After tanning all samples were neutralized, stuffed and dried out in equal conditions. The initial thickness of each sample at three points was determined. Further, each sample was pressed between flat pressing surfaces of a thickness-meter–plastometer, which was loaded until the compression equaled 0.54 MPa. One minute after applying the load, the thickness of the compressed sample was recorded. Then the sample was unloaded and the sample thickness without compression was measured. The measurements were subsequently conducted on each sample at three points. The obtained results were averaged. The general compression deformation as percentage from the starting thickness and deformation after unloading and after one hour after unloading (residual deformation) were determined. The received values were used for calculating the “momentary” elastic and “residual” deformation.

3. RESULTS AND DISCUSSION

In order to have an effective collagen structure during tanning it is necessary to have a moderate rate of derma swelling in liming. The combined usage of calcium hydroxide with natrium hydrosulphide allows to regulate the derma-swelling rate and, correspondingly, its porosity. It is linked with the formation of slightly soluble salts during interaction with carboxyl collagen groups, in comparison with the single calcium hydroxide processing.

According to the developed low waste technology [10], soaking is carried out with the use of surface-active agents, enzymatic and amine chemicals. This provides a uniform watering of the raw material during 4 hours at a temperature of 27–28°C and loosening the bond of hair with derma. At the first stage of liming, the hides are treated in the lime solution and in a mixture of hydro-sulphide and sodium sulphide. This ensures separation of the hair from the derma. The obtained hair is caught and can be used for additional products. At the second stage, the sulphide-lime liming with the decreasing consumption of calcium hydroxide and sodium sulphide is performed. As a result of the 2-stage liming, the derma with moderate degree of swelling (from 20 to 21%) is formed. This ensures an increasing yield in semi-finished item area by 3.0% (Table 3).

Table 3. The derma collagen condition after sulfide-calcic liming of hide with the hair destruction

Characteristics	After soaking	After derma liming	
		Temperature, °C	
		27–28*	19–20**
Swelling, %	0	21.0	26.0
Hydrothermal resistance, °C	64.0	54.0	52.0
Porosity of the pelt, %	34.5	56.0	55.0
Area changing, %	100.0	98.5	95.5

* Technology is being developed.

** Technology exists.

The rate of structural collagen transformation is determined by both the lime solution and technological process parameters, namely by the influence of the temperature, on which the duration of the relative processing and consumption of chemical materials depends. Increasing of the temperature speeds up the diffusion of reagents into derma structure and their interaction with the derma collagen. Simultaneously, while increasing the alkalinity of the working solution, the further inter-structure links (not only hydrogen but also ionic) take place between lateral radicals of polypeptide chains of collagen macromolecules accompanied by derma swelling and splitting of the collagen structure. As a result of this interaction the amid groups of asparagin and glutamine with the formation of complexes collagen–coom are recovered. Unlike the hydrate of alkali metals, calcium forms a poorly dissociative compound with carboxyl collagen groups. The tendency of changing hydrothermal resistance of derma collagen after liming can be stipulated by the calcium banding rate and difficult destruction of hydrogen links in hydrophobia areas [11]. As a result of liming, the isoelectric point of derma collagens decreases up to pH below 5.0. With pH over 13.0 it is possible to detach the guanidine groups of arginin.

The temperature decreasing to 20°C requires an increased consumption of chemical materials by more than three times and an increase in the duration of processing up to 24 hours. At this time, the derma collagen swelling rate is increased by 5%; that, in its turn, leads to the loss in area. This effect is stipulated by distortion of helices of polypeptide chains and collagen macromolecules and, correspondingly, decreases the microfibrils, elementary fibres and their bundles that leads to the increase in derma thickness and to the reduction of its area [6].

In order to complete the consolidation of the porosity of the collagen structure, the pelt is exposed to a number of physical and chemical actions. In the process of liming, under the effect of excessive amount of ammonic sulfate, the removal of calcium takes place as a result of double ammonium and calcium salt formations. This causes a lowering of the derma pH and derma swelling rate. The content of the destructed cellular substance is also reduced as a result of removal of the residual solution from structure (deliming). During further processing of

delimed derma by means of the proteolytic enzymatic agent, the further purification of the hair follicle from residual destructed keratin occurs (bating). The polysaccharides removal from fibril structure will promote the following splitting of derma collagens. In order to reduce pH of the surface layer or structure dehydrate, derma is exposed to the action of acid-salt mixtures or only concentrated salt solution with the aim of providing more exhaustive dehydration of microfibrils and increasing intermolecular distances (pickling and salting). Therefore, in the process of pre-tanning processing the derma collagen structure is exposed to a number of changes in the direction of its dispersion.

Basic stabilization of the derma collagen structure takes place under the influence of tanning compounds. In the tanning stage, the fragile hide collagen with the participation of tanning agents is transformed into soft, decay-resistant material which (after drying out) becomes leather. The tanning agents should have the capability to react with collagen (at least, in bifunctional manner) and have the size of tanning particles that they, on one hand, could penetrate into collagen fibrils, and, on the other hand, could act as cross-linking agents of the structure [12].

Over thousand years the vegetal matter was used as tanning agents. Like polyphenols, they joined the functional collagen groups, mainly through hydrogen linkages. From the beginning of the 20th century, the chrome salts (III) were used as tanning agents. The linkage of chrome compounds is carried out by means of the formation of a complex compound with carboxyl groups, located in side collagen chains. For the last 10 years, in order to manufacture eco-friendly leathers, the main role plays tanning with glutaric aldehyde in combination with both mineral and organic compounds. The tanning action of glutaric aldehyde is the result of the covalent cross-linking of amino groups of side collagen chains.

The technologies of tanning of non-splitting pelts from cattle hide with a thickness of 3–4 mm, using glutaric aldehyde, have been developed. The proposed technology of aldehyde-tannin tanning stipulates the use of glutaric aldehyde for preliminary treatment of the pelt before vegetable tanning instead of chrome compounds. Traditionally, vegetable tanning with preliminary treatment by chrome compounds is applied in the production of leather for the bottom of footwear. Due to the treatment by tannins, these leathers acquire the necessary density, fullness, strength and wearability. Besides producing leathers for the bottom of footwear, the combined tanning by chrome compounds and tannins can be used while manufacturing harness leathers and prosthetic juft (Russian leather).

The technology developed is especially intended for tanning harness leathers and prosthetic juft. The tanning of harness leathers differs from the tanning of leathers, applied for the bottom of footwear by more moderate, mild mode. While comparing the tanning of sole leathers with the tanning of harness ones, it should be mentioned that the latter is carried out at higher water-to-pelt ratio. Taking into account lower consumption of tannins, it ensures a decreasing concentration of tanning solutions (not more than 100 g/l). The general duration of tanning is shorter. The tanning temperature is also much lower. The optimal complex of

physico-mechanical indications of the structured collagen was obtained by using the mimosa tannins with a consumption of 15–20% in order to increase the hydrothermal resistance of the derma. The derivatives of heterocyclic compounds of oxazolidine class for pH correction were used.

The technology of combined tanning with partial replacing of chrome compounds by glutaric aldehyde and aluminum compounds also assumes the usage of heterocyclic compound derivatives of oxazolidine class for pH correction and for the increase in basicity [13]. For all this, the consumption of tanning agents constitutes several percents of the hide weight: glutaric aldehyde 2–4%, aluminum compounds 1–2%, while re-calculating in Al₂O₃ and chrome compounds 0.5–0.75% by re-calculating in Cr₂O₃. The main characterizations of different derma collagen types for tanning are given in Table 4.

The data in Table 4 indicate that there are substantial differences of elastoplastic properties of the derma collagen, which has been treated by the combinations of tanning agents. The difference in elastic characteristics of leathers of various kind of tanning is caused by different intensity of “cross-linking” of collagen chains. The formation of strong cross linkages between collagen chains during tanning leads to sharp changes of the derma collagen deformation character and, in particular, to the change of the role of relaxation processes. This is most distinctly seen during changing the thickness of derma samples in compression [9]. The more water-resistant cross links between polypeptide chains are formed, the shorter the sectors of the chains become and in this connection these sectors can be deformed easily and they recover faster their primary configuration after the tension is stopped. It is accompanied by the growth of

Table 4. Properties of derma collagen of different types of tanning agents

Index	Non-tanning	Conventional vegetable tanning	Consumption of glutaric aldehyde while tanning, %						
			Aldehyde-tannin		Aldehyde-alumchrome				
			2	4	2	4			
General deformation in compression, % from initial thickness	50.6	12.1	29.1	12.9	18.1	17.5			
Percentage from general deformation under compression, %			Momentary elastic deformation	42.5	52.1	3.9	62.7	56.2	73.2
			Elastic after-action	55.7	28.1	93.3	23.9	34.7	12.7
			Residual deformation	1.8	19.8	2.7	13.3	9.06	14.09
Apparent specific gravity, kg/m ³	1.28	0.71	0.65	0.58	0.55	0.53			
Volume yield, cm ³ /100 g protein	92	308	265.6	288.6	241.3	251.8			
Relative elongation at stress 9.8 MPa, %	60.0	9.3	18.0	25.0	44	41			
Tensile strength, MPa	21.8	32.2	33.9	30.63	32.0	34.7			
Shrinkage temperature, °C	60	88	95	96	91	93			

“momentary” elastic deformation. Besides, while comparing the derma deformability in compression with the corresponding formation indices of its volume, the relationship between these parameters become obvious. The less is the general derma deformation index in compression, the higher is the index of volume formation, and the less is the shrinkage during drying. As a result of appearance of new strong cross collagen linkages, the reduction in flexibility takes place, the structural derma elements become less moveable and this leads to the increase of the rigidity of the leather. As shown in Table 4, the usage of glutaric aldehyde during tanning stimulates obtaining of soft, elastic leathers with great yield in leather volume.

The molecules of tannins interact only with the active groups of those sectors of polypeptide chains, which form the amorphous areas of unordered collagen structure or on the border of division between ordered formations [14]. The increased softness of the leather, tanned using glutaric aldehyde can most likely be explained by the fact that, due to small size, the glutaric aldehyde molecules penetrate into boundary areas of amorphous areas of the collagen structure.

4. CONCLUSIONS

1. The features of the micro- and macrostructure of derma collagens by tanning have been investigated. It has been shown that the realized collagen transformations require a systematic approach by developing ecologically safe technologies. Determination of the interrelation between the leather structure and its properties is required for the regulation of the properties of the consumption leather of broad assortment.
2. In accordance with the developed liming technology, with decreased consumption of calcium hydroxide and sodium sulphide, derma with moderate swelling by 20–21% is formed and this results in increasing yield in the pelt area after liming by 3.0%. This is the necessary condition for effective fixation of the collagen structure in tanning. This also provides leather formation for special purposes with maximum usage of the raw material.
3. The combined aldehyde-tannin tannage, according to the developed technology, provides strong, flexible leather with fine elastoplastic properties. It is confirmed by the decrease of the total deformation under compression by 50–60% in comparison with leathers of conventional vegetable tannage.
4. The usage of glutaric aldehyde in combined tannage allows forming elastic leather with higher resilience. This, probably, can be explained by small molecular size of glutaric aldehyde, which easily penetrates into boundary zones of amorphous spheres of the collagen structure.
5. Using glutaric aldehyde in combined tannage also allows to decrease the consumption of toxic chrome compounds by 2–3 times or even to fully exclude them. This considerably facilitates the purification of effluents and promotes the improvement of the ecological situation.

ACKNOWLEDGEMENT

This work was supported by the Ukrainian Budget (project #16-07-06DB).

REFERENCES

1. Heidemann, E. Die gegenwärtigen Kenntnisse von Kollagen. *Das Leder*, 1991, **42**, 21–36.
2. Heidemann, E. Eine erweiterte Theorie der Kochfesten Gerbung, Lokalisation im Kollagen. *Das Leder*, 1994, **45**, 2–12.
3. Reich, G. Collagen report: A review about the present state. *Das Leder*, 1995, **46**, 192–199.
4. Cot, J. An imaginary journey to the collagen molecule for a better understanding of leather waste treatments. *JALCA*, 2004, **88**, 322–350.
5. Kutyaniin, G. I., Ostashenko, L. S., Urudzhev, R. S. and Golubyatnikova, A. T. On reducing the crystalloid structure rate as a result of tanning. *Izvestiya VUZov, Tekhnologiya legkoj promyshlennosti*, 1974, **2**, 60–64 (in Russian).
6. Mikhailov, A. N. *Collagen of Coverlet and Basis for its Processing*. Legkaya promyshlennost', Moscow, 1971 (in Russian).
7. Heidemann, E. Überlegungen, wie die Massen von Gerbstoffen und Fetten in der Kollagenstruktur eingelagert werden. *Das Leder*, 1995, **46**, 149–154.
8. Danylkovych, A. G. and Chursin, V. I. *Practicum for Chemistry and Leather and Fur Technology*. Textbook. Tsentralnyj nauchno issledovatel'skij institut kozhevennoj promyshlennosti, Moscow, 2002 (in Russian).
9. Kutyaniin, G. I. *The Study of Physics and Mechanical Properties of Leather*. Gosudarstvennoe izdatel'stvo mineralnoj i tekstilnoj promyshlennosti, Moscow, 1956 (in Russian).
10. Lischuk, V. I. and Danylkovych, A. G. Cattle unhairing and liming with hair preservation. *Visnik Kievskogo natsional'nogo universiteta tekhnologij i dizajna*, 2005, **3**, 73–77 (in Ukrainian).
11. Urudzhev, R. S. and Myrzaliev, A. A. Temperature of fluidity of leather collagen and its practical meaning. *Kozhevenno-obuvnaya promyshlennost'*, 2004, **4**, 24–27 (in Russian).
12. Reich, G. Herstellung und Struktur-Eigenschaftsbeziehungen von Leder. *Leder & Haute Markt*, 2002, **10**, 31–39.
13. Plavan, V. P. Development of the technology for aldehyde-vegetable tanning. *Visnyk KNUTD* (Kiev), 2005, No. 6, 82–89 (in Ukrainian).
14. Kutyin, G. I. and Kutyaniina, L. G. The grounds for development of methods for increasing the leather softness. *Kozhevenno-obuvnaya promyshlennost'*, 1998, **1**, 33–34 (in Russian).

Kollageeni struktuuris naha töötlemisel tekkivad muutused

Viktor Lischuk, Viktoriya Plavan ja Anatolij Danilkovich

On uuritud kollageeni struktuuri naha lupjamisel ja parkimisel. Mõõdukas pundumiskiirus parkimisel tagab derma struktuuri tõhusa kinnistumise. Ristseotiste teke lupjamisel tõstab naha elastsust. Parkimisel tungivad glutaaraldehüüdi molekulid kollageeni struktuuri amorfsetesse piirialadesse ja tekitavad püsivaid ristseotisi, muutes naha pehmemaks ja elastsemaks, ühtlasi vähendades kroomiühendite kulu.